

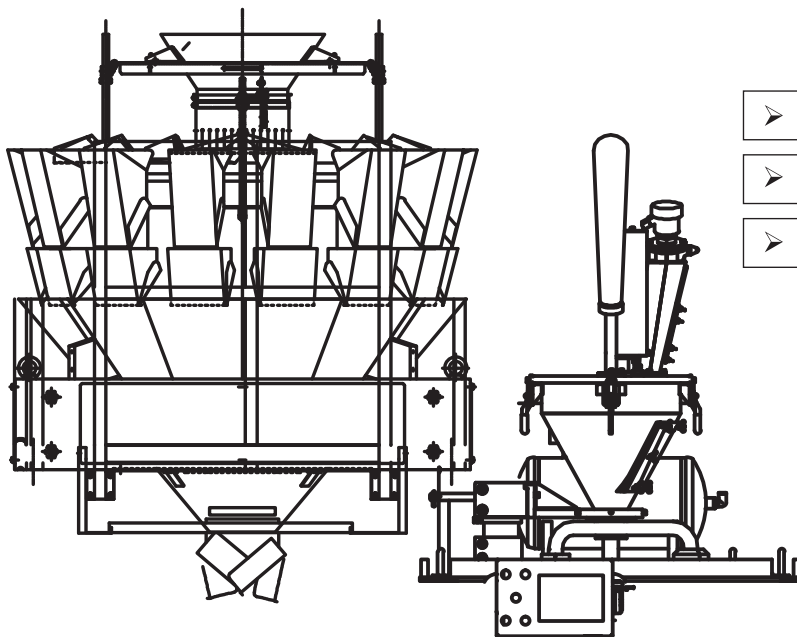

V F F S

NICHROME

FILLING SYSTEMS



- High Speed
- Servo Mechanism
- Accurate



NICHROME
Packaging Solutions

An ISO 9001:2008 and ISO 22000:2005 Certified Company

www.nichrome.com

Intelweigh



Intelweigh MHW 10H/14H

- Combination Volume: Max. 3000 cc
- Bucket Volume: 1.3 liters
- Weighing Range: 10 gm to 1000 gm
- Accuracy: 0.2 gm to 2 gm
- Display: 7 inch touch screen
- Operational Speed: Max. 70 dumps / min
- Weigh heads no: 10
- Weighing method with load cell
- Buckets open / close with stepper motor
- Program Number: Max. 100
- Product Contact Parts: SS 304
- Power Requirements: AC 200/220/230/240 V +/- 10%; 50/60 Hz. Single phase, 1.5 KVA
- IP Protection Class: IP 54
- Temperature: -10 to 40 degree centigrade
- Humidity: 35 to 85% non-condensation
- Vibration No power machine near the site
- Others No direct sunshine, no high temperature devices, no direct wind
- Dimensions: 950 x 1150 x 1330 mm
- Weight: 350 Kg approx.
- Applications: Tea, sugar, pulses, rice, snacks, and other free-flowing products
- Product Length: Max. 60 mm



Intelweigh Combi

- Built in safety door guards with machine off interlock
- Tool-less disassembly of bucket for ease of cleanup and changeover
- Aesthetically improved machine ensuring safety
- Available in broad range of filling capacities
- Dumps/minute: 40 to 45 for 1kg/ 15 to 20 for 5 kg
- Accuracy % sd: 0.5%/0.2%
- Weighing Range: 50 gm to 2 kg/500 gm to 5 kg
- Air Consumption: 0.15 CFM at 6 bar
- Connected Load/Head: 0.25 kW
- Applications: Seeds, whole spices, grocery products, Indian namkeen

Easyfill



Easyfill Servo Auger

- Filling capacity: 5 cc to 2000 cc
- Level sensor for high level
- Servo driven auger mechanism
- Robust construction
- Facilitates easy cleaning
- MOC of contact parts: SS-304 or SS-316 depending on product
- Gaskets: PTFE / Food grade Silicon rubber
- Hygienic construction
- Structure: M.S. powder coated
- Hopper: Inside buffing, outside Matt finish
- Auger: Buffing / Teflon coating / Nedox coating as per customer requirement



NICHROME
Packaging Solutions

NICHROME INDIA LTD. Safire Park Galleria, 4, Pune-Mumbai Road, Shivajinagar, Pune - 411 005, India
Tel.: +91 - 20 - 6601 1001 Fax: +91 - 20 - 6601 1010 E-mail: marketing@nichrome.com www.nichrome.com

Service Centres & Offices at: Delhi | Kolkata | Mumbai | Bangalore | Hyderabad | Chennai | Ahmedabad | Chandigarh | Kanpur
ASEAN | MIDDLE EAST | SAARC | RUSSIAN FEDERATION & CIS | AFRICA | USA

Packaging Solutions For: Liquids • Grains • Powders • Seeds • Snacks • Pharma • Personal Care