

BULK PACKING MACHINE: SOLID



KEY FEATURES:

- NO BAG NO FILL
- AUTO BAG CLAMPING.
- HDPE WOVEN, PP , PAPER , VALVE TYPE BAGFRIENDLY MACHINE.
- DOUBLE THREAD, SINGLE THREAD AUTO CUTTER STITCHING MACHINE.
- PLC CONTROLLED MACHINE.
- BULK & DRIBLE FEED .
- NET WEAHER & GROSS WEAHER BOTH OPTION AVAILABLE.
- SAFETY ENCLOSURES WITH INTERLOCKS FOR ROTARY PARTS.
- BAG TILTING & ALIGNMENT ATTACHMENT.

BULK PACKING MACHINE – GENERAL ARRANGEMENT DRAWING

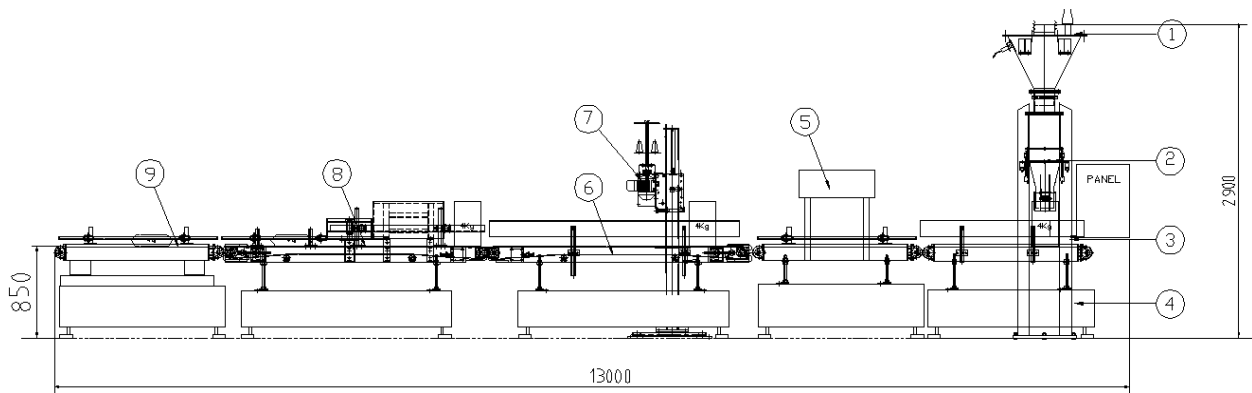

SR.NO.	ITEM DESCRIPTION	QTY
1	INTERMEDIATE HOPPER	1
2	FILLER	1
3	BAG GRIPPER	1

4	BAG TAKE OFF CONVEYOR	1
5	BAND SEALER	1
6	STITCHING CONVEYOR	1
7	STITCHING MACHINE	1
8	BAG TILTING & ORIENTOR CONVEYOR	1
9	BAG CONVEYOR	1

Bottle Filling Product Range:

PRODUCT	SKU	SPEED	FLOOR SPACE
RICE , GRAIN , SUGAR, PULSES, AGRO CHEMICAL GRANULLES , ATTA , MAIDA, CAKE MIX	5 KGS TO 50 KGS	UP TO 20 BPM	3.5 MTRS WIDE X 13 MTRS LONG X 3 MTRS HEIGHT

SPECIFICATION	BAG WIDTH		HEIGHT	
	MIN.	MAX.	MIN.	MAX.
BAG (OPEN MOUTH)	250 mm	Ø 800 mm	300 mm	1100 mm
BAG (VALE TYPE)	Ø 50 mm	Ø 80 mm	300 mm	1100 mm